

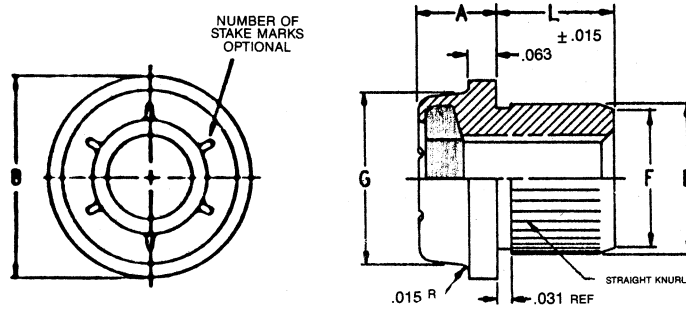

The bright purple nylon insert identifies Tork Lok Nuts and denotes precision manufacture from the finest materials, to assure top product performance. "Look for the Royal Purple Insert!"



ND SPLINE NUT



CONTINENTAL-AERO PART NUMBER	THREAD	A ±.015	B ±.015	D		F REF	G REF	RECOMMENDED INSTALLATION HOLE SIZE		L ±.015	MINIMUM AXIAL STRENGTH POUNDS	APPROX. WEIGHT LB/100
				MIN	MAX			MIN	MAX			
29ND8-82	.1640-32UNC-3B	.172	.438	.321	.325	.287	.370	.312	.316	.125	1,720	.57
29ND10-82										.156		.62
29ND12-82										.188		.67
28ND14-82										.219		.72
29ND16-82										.250		.77
29ND20-82										.313		.87
29ND8-02	.1900-32UNF-3B	.172	.438	.321	.325	.287	.370	.312	.316	.125	2,460	.53
29ND10-02										.156		.58
29ND12-02										.188		.63
29ND14-02										.219		.68
29ND16-02										.250		.73
29ND18-02										.281		.78
29ND20-02	.313	.83										
49ND8-048	.2500-28UNF-3B	.188	.563	.384	.388	.350	.438	.375	.379	.125	3,750	.70
49ND10-048										.156		.80
49ND12-048										.188		.90
49ND14-048										.219		1.00
49ND16-048										.250		1.10
49ND20-048										.313		1.30
49ND24-048	.376	1.50										
49ND28-048	.438	1.70										
49ND8-054	.3125-24UNF-3B	.234	.625	.446	.450	.412	.500	.437	.441	.125	6,500	1.00
49ND10-054										.156		1.10
49ND12-054										.188		1.20
49ND14-054										.219		1.30
49ND16-054										.250		1.40
49ND20-054										.313		1.60
49ND24-054	.376	1.80										
49ND10-064	.3750-24UNF-3B	.281	.688	.509	.512	.475	.570	.500	.504	.156	11,000	1.30
49ND12-064										.188		1.40
49ND14-064										.219		1.50
49ND16-064										.250		1.60
49ND20-064										.313		1.80
49ND24-064										.376		2.00
49ND32-064	.500	2.40										
49ND28-070	.4375-20UNF-3B	.359	.750	.571	.575	.537	.660	.562	.566	.436	12,000	2.60
49ND22-080	.5000-20UNF-3B	.375	.875	.696	.700	.662	.770	.687	.691	.344	12,000	3.90
49ND28-080										.438		4.20

Material: Steel

Finish: As needed

Locking Insert: Purple nylon (250°F max. performance) white and staked available.

Torque: Per Continental-Aero procurement specifications.